

# **ROW HIPPER** *Operator's Manual*

**MODERN**  
**AG PRODUCTS, LTD.**

**YOU'RE ALWAYS AHEAD... WITH A MODERN BEHIND.**

P.O. BOX 790 • BEAUMONT, TX 77704  
409.833.2665 • 1.800.231.8198 FAX: 409.726.8333  
[www.modernusa.com](http://www.modernusa.com)

*Go Galvanized!*

# SAFETY SECTION

The **SAFETY ALERT SYMBOL**  indicates that there is a potential hazard to personal safety involved and extra safety precautions must be taken. When you see this symbol on your machine or in this manual, be alert and carefully read the message that follows it.

**DANGER:** Indicates an imminently hazardous situation which, if not avoided, will result in death or serious injury. This signal word is limited to the most extreme situations.

**WARNING:** Indicates a potentially hazardous situation which, if not avoided, could result in death or serious injury.

**CAUTION:** Indicates a potentially hazardous situation which, if not avoided, may result in minor or moderate injury. It may also be used to alert against unsafe practices.

## OPERATION

### **WARNING**

Know your controls and how to stop tractor and engine quickly in an emergency. **READ THIS MANUAL AND THE ONE PROVIDED WITH YOUR TRACTOR.**

To avoid accident or injury, do not allow anyone to operate this equipment without proper instructions. Any person who operates this equipment must be instructed in and be capable of the safe operation of the unit, its attachments and all controls.

Always wear relatively tight and belted clothing to avoid entanglement in moving parts. Wear sturdy, rough soled work shoes. Never operate tractor or implements in bare feet, sandals or sneakers.

### **DANGER**

Never permit any person other than the operator to ride or board the tractor at any time.

### **CAUTION**

Do not allow rides on disc at any time.

Disengage power takeoff and shift tractor into neutral before attempting to start engine.

### **WARNING**

Never allow anyone in front of or behind tractor while operating. Always look behind before operating tractor in reverse.

Never make a height adjustment while engine is running if operator must dismount from tractor.

Do not stop or start suddenly when going up or down hill. Avoid operating on steep slopes.

# SAFETY SECTION

## **WARNING**

Use extreme care and maintain minimum ground speed when transporting on hillside, over rough ground and when operating close to ditches or fences.

Be alert for holes in terrain and other hidden hazards.

Always comply with all state and local lighting and marking requirements when operating on highways.

Watch for traffic when crossing roadways.

Reduce speed on slopes and sharp turns to prevent tipping or loss of control. Be careful when changing directions on slopes.

Stop tractor immediately upon striking an obstruction. Turn engine off, inspect disc and repair any damage before resuming operation.

Never place hands or feet under disc while tractor engine is running or when disc is not properly secured with safety stands or blocks.

Take all possible precautions when leaving tractor unattended. Set parking brake, stop engine and remove key from ignition.

Front tractor weights or front tire ballast will enhance front and stability. Approximately 20% of tractor and equipment weight should be on the front wheels.

## **MAINTENANCE**

### **DANGER**

Never work without safety blocks.

### **WARNING**

Keep engine free of grass, leaves or excess grease to reduce fire hazard.

Do not change engine governor settings or overspeed engine.

Keep tractor and disc in good operating condition and all safety devices in place.

Periodically tighten all bolts and nuts and check that all cotter pins are properly installed to ensure disc is in a safe condition.

# ROW HIPPER ASSEMBLY

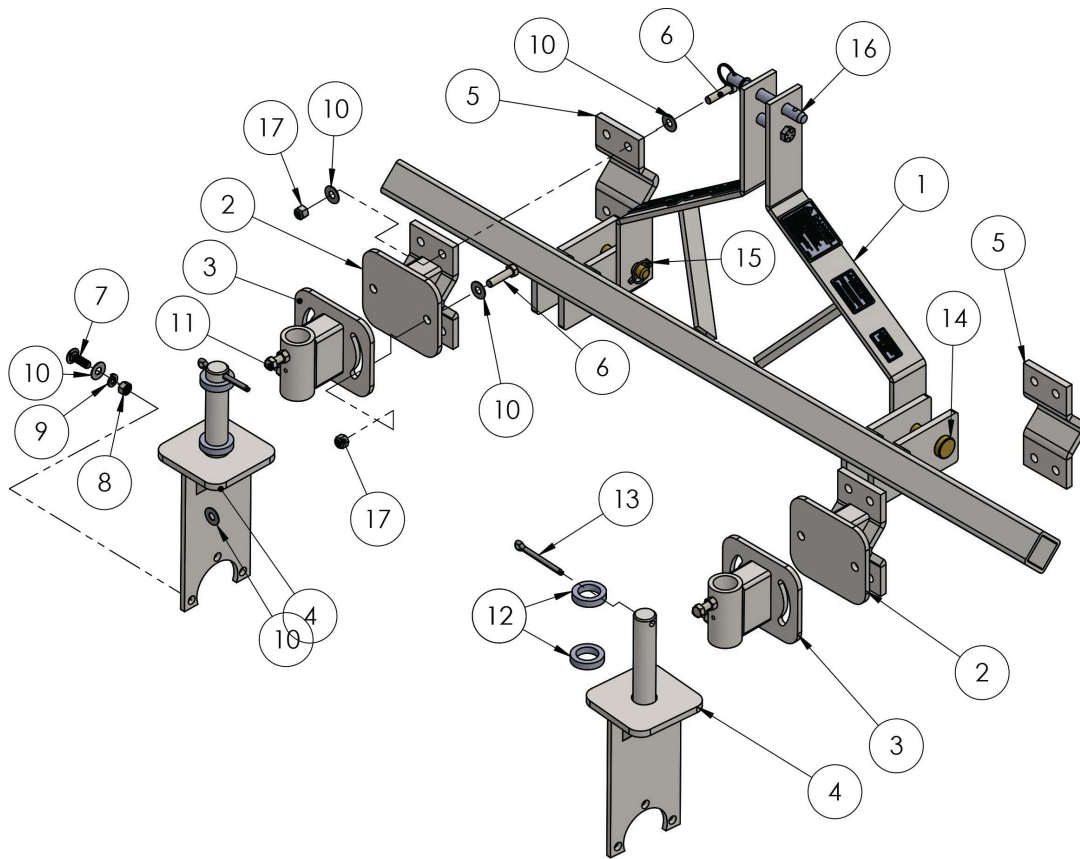

ITEM NO.	PART NUMBER	DESCRIPTION	QTY.
1	109-4764	60" TOOL BAR ASSEMBLY	1
3	101-5400	GANG SIDE ASSEMBLY	2
2	101-5401	FRAME SIDE ASSEMBLY	2
4	101-5402	GANG BRNG HANGER ASSEMBLY	2
5	610-2015	Clam Shell .50x4x10 Flat Bar Att Tab	2
6	412-2085	BOLT 1/2-13x2.5	12
7	412-6769	Carriage Bolt 1/2-13x1.5	6
8	412-0058	NUT 1/2-13 GD5 ZP	6
9	412-0072	1/2 LOCK WASHER	6
10	412-0072-01	1/2 FLAT WASHER	26
11	412-2042-02	BOLT 1/2-13x1.5-NC GD5	4
12	101-7552	T-W SPACER 2.25x.5	4
13	412-0081	Zinc-Plated - Carbon Steel Cotter Pin	2
14	412-6389	PULL PIN 7/8 x 5-1/2, CAT I	2
15	154-1533	LYNCH PIN 5/16x1/4x1 11/16-1 9/16	2
16	150-1464	TOP LINK PIN 3/4x4-3/4 USABLE CAT1	1
17	412-3243	1/2 Nylon-Insert Locknut	12

# BLADE PACK ASSEMBLY

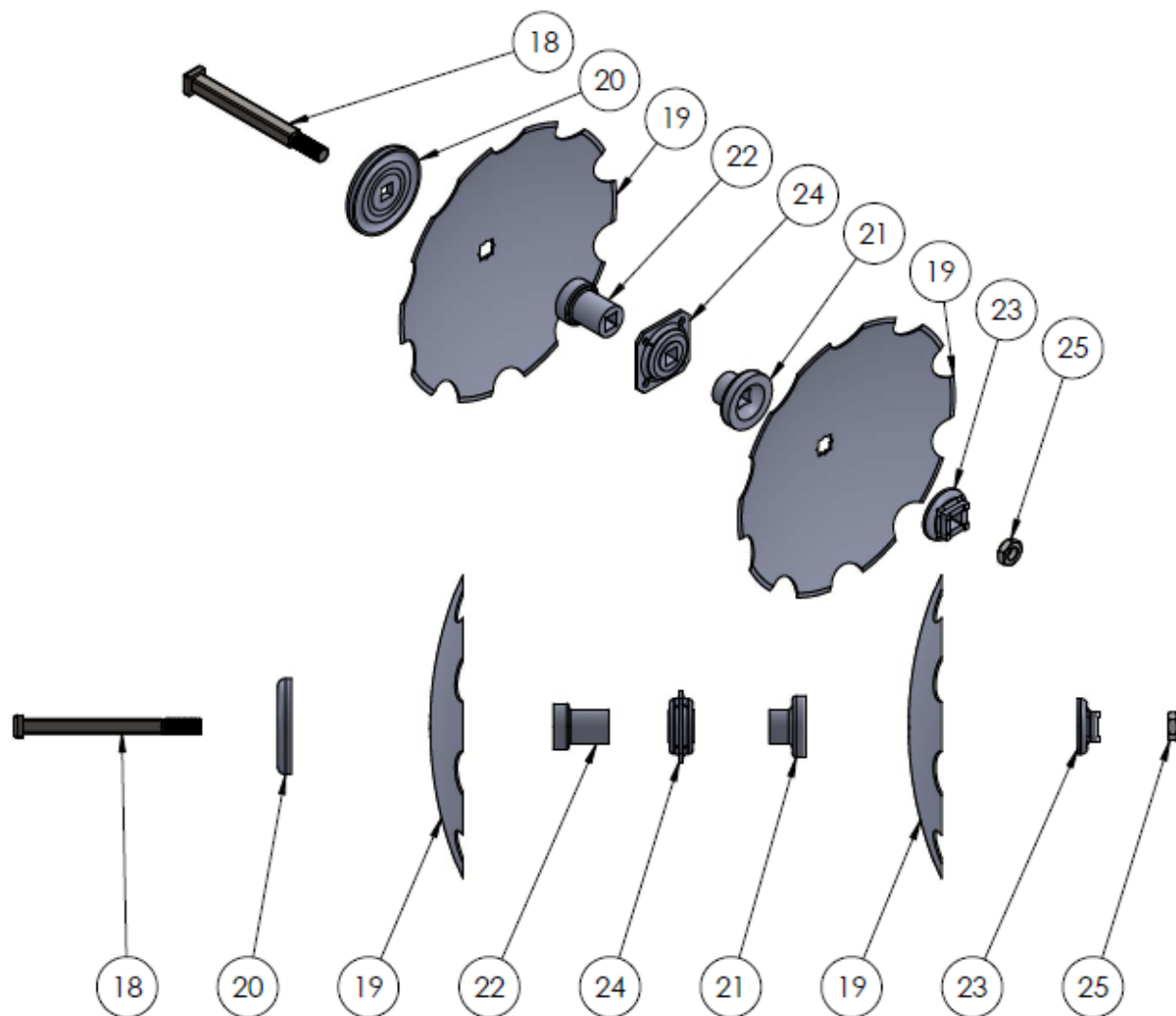

ITEM NO.	PART NUMBER	DESCRIPTION	QTY.
18	412-0015	ARBOR BOLT	1
19	411-5921	Disc Blade	2
20	411-6948	Bumper washer	1
21	411-7156	Disc gang spacer- mb1, 2-3/8"	1
22	411-7364	Disc gang spacer- mb2, 3-5/8"	1
23	411-7780	Outer end washer	1
24	411-8404-01	Disc Sealed Bearing	1
25	412-2290	1" NYLOCK JAM NUT	1

**\*\* Quantities listed above are PER PACK \*\***

# ASSEMBLY SECTION

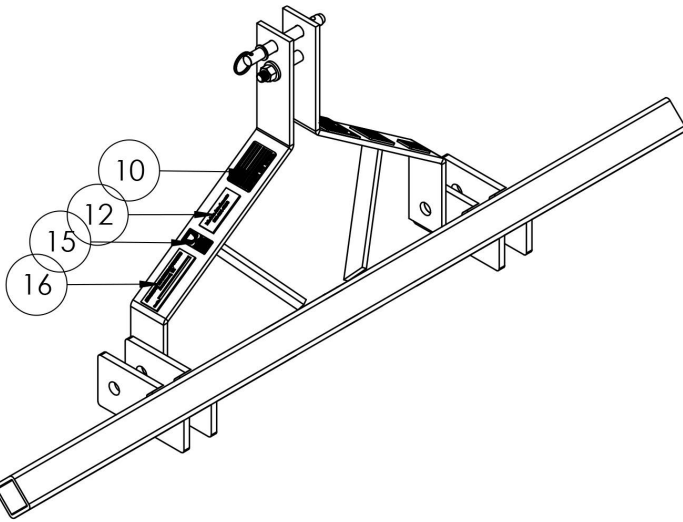

ITEM NO.	PART NUMBER	DESCRIPTION	QTY.
10	490-1023	US FLAG DECAL 4X2.5	1
11	490-1024	CAUTION DECAL	1
12	490-2003	MODERN ATTACHMENT DECAL	1
13	490-5010	DANGER DECAL	1
14	490-GALVCOAT	GALVANIZED COATING	1
15	490-FEMA	FEMA DECAL	1
16	490-2000	MODERN SER. NO. DECAL	1

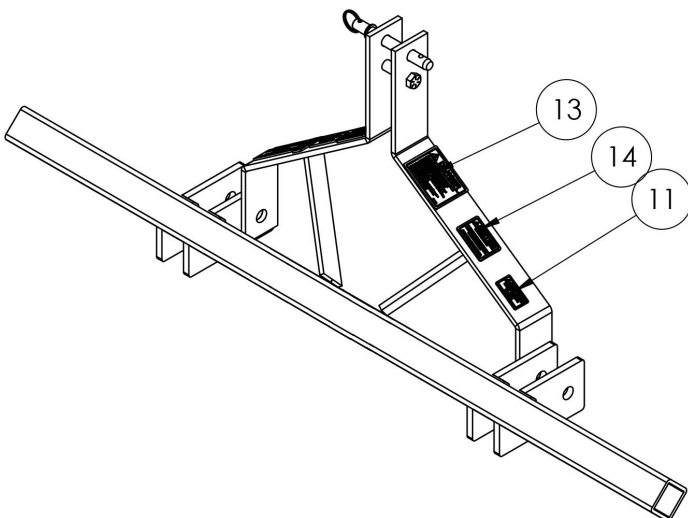

# LIMITED WARRANTY POLICY

Modern, Inc. warrants its products for a period of one year after date of sale by authorized dealer to be free from defects in material and workmanship, and will replace at its factory, any parts that will be returned, with shipping charges prepaid, and when examined by us, will disclose it to be defective. This warranty will not apply to implements or parts that have been subjected to misuse, negligence, accident, or that have been altered or repaired.

1. Parts may not be returned without authorization by ModernAg Products.
2. All products returned under warranty inspection claim must be returned PREPAID to our factory.
3. Our obligation under the above warranty is limited to repair or replacement at our factory of any part or parts which Modern, Inc. decides to be defective.
4. Products or parts that have been examined by Modern, Inc. and determined to be improperly operated, damaged by accident or negligence, field repaired or altered, are not covered by this warranty.
5. Modern, Inc. reserves the right to change our specification and designs at any time.
6. This warranty will not obligate Modern, Inc. to bear any cost of labor for field replacement, testing, or adjustment.

## LIMITED WARRANTY POLICY & REGISTRATION

DEALER: I hereby certify that:

1. The machine has been correctly assembled in accordance with manufacturers instructions.
2. All bolts have been checked and zerks filled with grease.
3. All other pre-delivery checks have been completed as per operators manual.
4. Purchaser was given operators manual and instructed in safe and correct usage of machine and on limitation of warranty.
5. All safety guards and safety signs have been placed on machine.
6. Purchaser was given operator's manual and instructed in safe and correct usage of machine and on limitation of warranty.
7. Machine was tested and operates correctly.

PURCHASER: I hereby certify that:

1. The machine is correctly assembled.
2. Receipt of the operators manual which I have read and clearly understood.
3. I have a clear understanding of the warranty limitations.
4. I have a clear understanding on the correct and safe operation of the machine
5. That the machine needs regular maintenance as per instructions in operators manual.
6. I have a clear understanding on the capacity of this machine and am aware of its limitations.

MODEL \_\_\_\_\_ SERIAL # \_\_\_\_\_

DEALER \_\_\_\_\_ DATE DELIVERED \_\_\_\_\_

DEALER'S STAMP

MAIL TO:

PURCHASERS ADDRESS: